

FMC 120

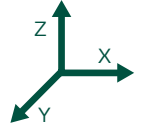

✓ = standard ○ = optional

TECHNICAL FEATURES

WORKING AREAS

- X axis top face
- Y and Z axes for machining on 3 faces of profile
- Pneumatic rotation of work table 0°; 90°; 180°
- Rotation of work table by intermediate angles with manual stop

2675 mm
180 mm x 120 mm

✓
○

PROFILE POSITIONING AND LOCKING

- Vices with manual positioning
- Vices with pneumatic brake
- Max number of vices
- Fixed and manual stop
- Oversized

4
○
6
2
✓

ELECTROSPINDLE

- Electrospindle 3 kW 17000 rpm
- Rigid tapping
- Air cooled
- Tool collet

✓
○
✓
ISO30

TOOL MAGAZINE

- Manual 6 location tool magazine on head
- Automatic 5 location tool magazine

✓
○ (as an alternative to the standard magazine)

TOOL LUBRICATION

- Minimum quantity lubrication
- Lubrocooling

✓
○

CONTROL AND SOFTWARE

- 24" screen
- Wireless bar-code reader
- FST Cam 4
- LOLA ready

✓
○
✓
✓

FMC 120

Maximum workable profile on three faces with tool with 110 mm spindle end projection and work table rotation 0°/90°/180°

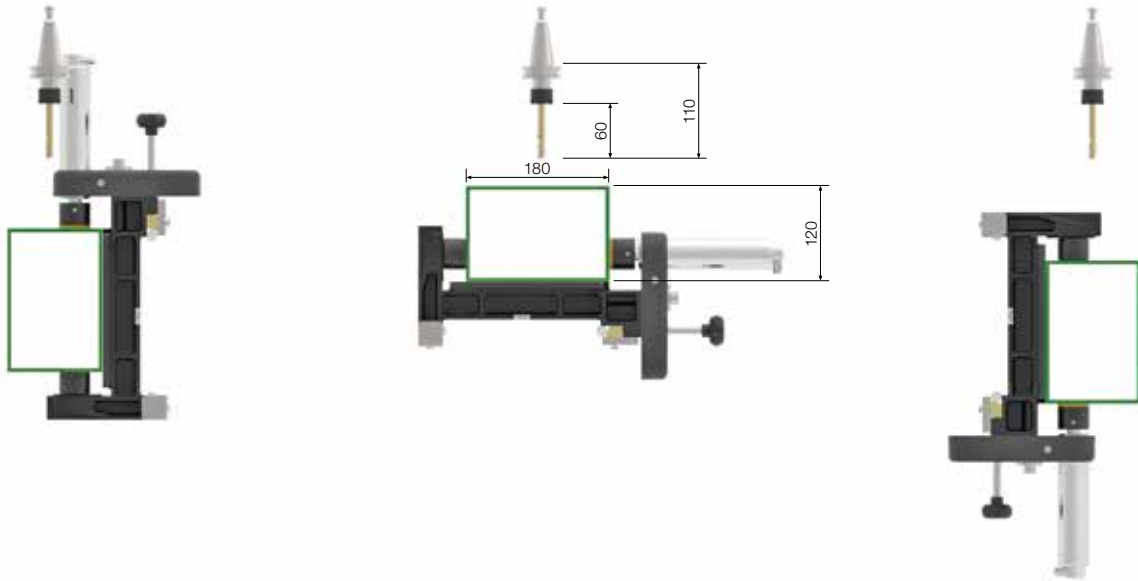

Maximum profile machinable on three surfaces with tool protruding 110 mm from the spindle nose

